

- Q.2 a. What is open and closed loop control? Discuss advantages and disadvantages of each.

**Answer:**

**Open Loop System:**

**Advantages:**

1. **Simplicity and stability:** they are simpler in their layout and hence are economical and stable too due to their simplicity.
2. **Construction:** Since these are having a simple layout so are easier to construct.

**Disadvantages:**

1. **Accuracy and Reliability:** since these systems do not have a feedback mechanism, so they are very inaccurate in terms of result output and hence they are unreliable too.
2. Due to the absence of a feedback mechanism, they are unable to remove the disturbances occurring from external sources.

**Closed Loop System:**

**Advantages:**

1. **Accuracy:** They are more accurate than open loop system due to their complex construction. They are equally accurate and are not disturbed in the presence of non-linearities.
2. **Noise reduction ability:** Since they are composed of a feedback mechanism, so they clear out the errors between input and output signals, and hence remain unaffected to the external noise sources.

**Disadvantages:**

1. **Construction:** They are relatively more complex in construction and hence it adds up to the cost making it costlier than open loop system.
2. Since it consists of feedback loop, it may create oscillatory response of the system and it also reduces the overall gain of the system.
3. **Stability:** It is less stable than open loop system but this disadvantage can be struck off since we can make the sensitivity of the system very small so as to make the system as stable as possible.

- b. Determine the transfer function  $V_o(s)/V_i(s)$  of the electrical system given in Fig.2

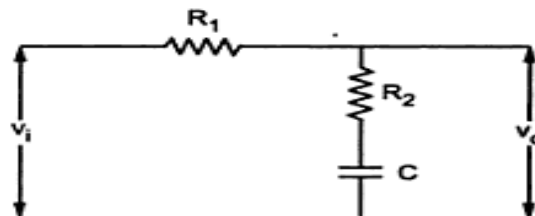

**Fig.2**

**Answer:**

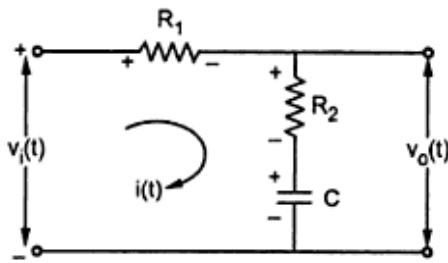

Fig. 3.3(a)

$v_i(t)$  = Input

$v_o(t)$  = Output

$$\therefore \text{T.F.} = \frac{V_o(s)}{V_i(s)}$$

Applying KVL to the loop,

$$-i(t) R_1 - i(t) R_2 - \frac{1}{C} \int i(t) dt + v_i(t) = 0$$

...(1)

Taking Laplace transform and neglecting initial conditions,

$$I(s) R_1 + I(s) R_2 + \frac{1}{sC} I(s) = V_i(s)$$

$$\therefore I(s) = \frac{V_i(s)}{R_1 + R_2 + \frac{1}{sC}} = \frac{sC V_i(s)}{sC(R_1 + R_2) + 1} \quad \dots(2)$$

The output equation is,

$$v_o(t) = i(t) R_2 + \frac{1}{C} \int i(t) dt \quad \dots(3)$$

Taking Laplace transform,

$$V_o(s) = I(s) R_2 + \frac{1}{sC} I(s) = I(s) \left[ R_2 + \frac{1}{sC} \right]$$

Using (2) in (4),  $V_o(s) = \left\{ \frac{sC V_i(s)}{sC(R_1 + R_2) + 1} \right\} \left[ \frac{sC R_2 + 1}{sC} \right]$

$$\therefore \text{T.F.} = \frac{V_o(s)}{V_i(s)} = \frac{sC R_2 + 1}{sC(R_1 + R_2) + 1}$$

**Q.3** Determine the transfer function  $C(s)/R(s)$  for the block diagram as shown in Fig.3 by drawing its signal flow graph and using the Mason's gain formula

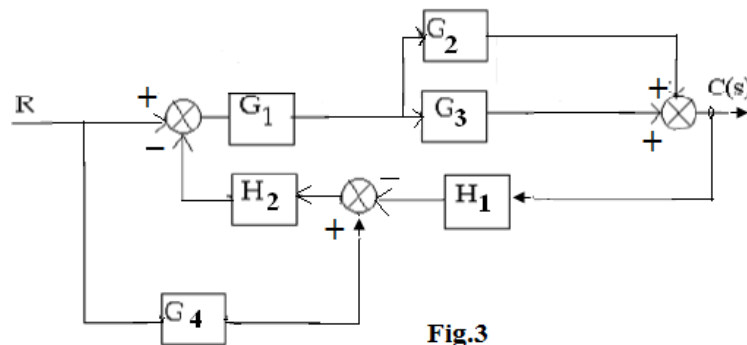
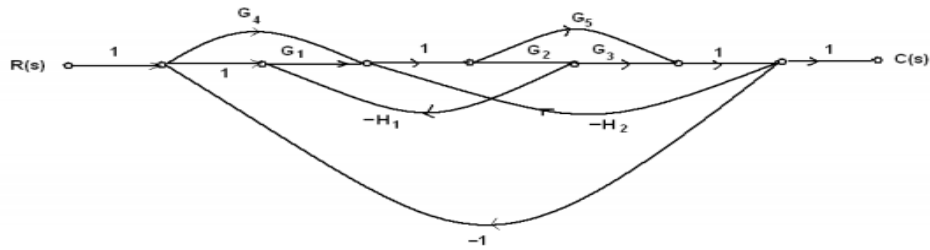

Fig.3

**Answer:**

SIGNAL FLOW GRAPH OF THE BLOCK DIAGRAM:



Mason's gain formula

Overall system gain is given by

$$T = \frac{1}{\Delta} \sum_k P_k \Delta_k$$

$P_k$  – gain of  $k^{\text{th}}$  forward path

$\Delta$  = det of the graph

= 1 – sum of loop gains of all individual loops + (sum of gain products of all possible combinations of two non-touching loops) – (sum of gain products of all possible combinations of three non touching loops) + .....

$\Delta_k$  = the value of  $\Delta$  for that part of the graph not touching the  $k^{\text{th}}$  forward path.

There are four path

gains

$$P_1 = G_1 G_2 G_3$$

$$P_2 = G_4 G_2 G_3$$

$$P_3 = G_1 G_5$$

$$P_4 = G_4 G_5$$

Individual loop gains are

$$\begin{aligned}
 P_{11} &= -G_1 G_2 H_1 \\
 P_{21} &= -G_5 \\
 &H_2 \\
 P_{31} &= -G_2 G_3 H_2 \\
 P_{41} &= \\
 &-G_4 G_5 \\
 P_{51} &= \\
 &G_1 G_2 G_3 \\
 P_{61} &= \\
 &G_4 G_2 G_3 \\
 P_{71} &= \\
 &-G_1 G_5
 \end{aligned}$$

There are no non touching loops

$$\Delta = 1 - (G_1 G_2 H_1 + G_5 H_2 + G_2 G_3 H_2 + G_4 G_5 + G_1 G_2 G_3 + G_4 G_2 G_3 - G_1 G_5)$$

$$\begin{aligned}
 T &= \frac{\Delta_4}{\Delta} \\
 &= \frac{G_1 G_2 G_3 + G_4 G_2 G_3 + G_1 G_5 + G_4 G_5}{1 + G_1 G_2 H_1 + G_5 H_2 + G_2 G_3 H_2 + G_4 G_5 + G_1 G_2 G_3 + G_4 G_2 G_3 + G_1 G_5}
 \end{aligned}$$

**Q.4** a. Explain the construction and working principle of stepper motor write its applications.

**Answer:**

A stepper motor transforms electrical pulses into equal increments of shaft motion called steps. It has a wound stator and a non-excited rotor. They are classified as variable reluctance, permanent magnet or hybrid, depending on the type of rotor. The no of teeth or poles on the rotor and the no of poles on the stator determine the size of the step (called step angle). The step angle is equal to 360 divided by no of step per revolution.

**Operating Principle:**

Consider a stepper motor having 4-pole stator with 2-phase windings. Let the rotor be made of permanent motor with 2 poles. The stator poles are marked A, B, C and D and

they excited with pulses supplied by power transistors. The power transistors are switched by digital controllers a computer. Each control pulse applied by the switching device causes a stepped variation of the magnitude and polarity of voltage fed to the control windings.

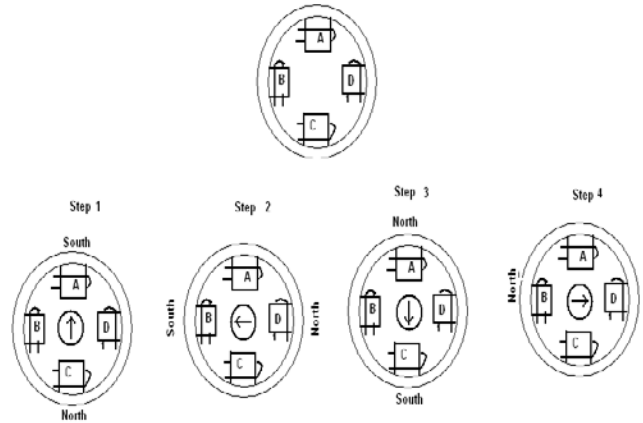

Figure: Stepper Motor

Stepper motors are used in computer peripherals, X-Y plotters, scientific instruments, robots, in machine tools and in quartz-crystal watches.

- b. A unity feedback control system has the open-loop function as  $\frac{5}{s(s+2)}$ .

Find the response of the system considering controller transfer function as  $(2s+3)$  and with a step input.

**Answer:**

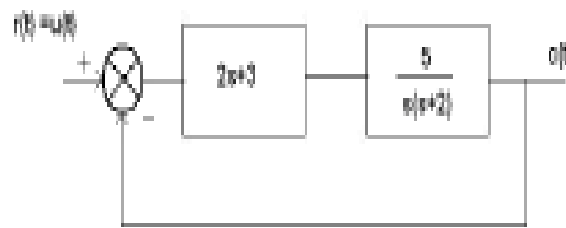

$$G(s) = \frac{5(2s+3)}{s(s+2)}$$

$$\begin{aligned}
 M(s) &= \frac{G(s)}{1+G(s)H(s)} \\
 &= \frac{5}{s(s+2)} \cdot \frac{(2s+3)}{(2s+3)} \\
 &= \frac{5}{1 + \frac{5}{s(s+2)}(2s+3)} \\
 &= \frac{10s+15}{s^2+12s+15} \\
 \frac{C(s)}{R(s)} &= \frac{10s+15}{s^2+12s+15} \\
 C(s) &= \frac{10s+15}{s^2+12s+15} \cdot \frac{1}{s} \\
 C(s) &= \frac{10s+15}{s(s^2+12s+15)} \\
 C(s) &= \frac{10s+15}{s(s+10.58)(s+1.4174)}
 \end{aligned}$$

applying inverse laplace transform

$$c(t) = -0.9367 \cdot \exp(-10.58 \cdot t) - 0.0636 \cdot \exp(-1.4174 \cdot t) + 1.0003$$

- Q.5** a. The open loop function of unity feedback system is given by

$$G(s) = \frac{4}{(s+1)}$$

Find the nature of response of the closed loop system for a unit step input. Also calculate rise time, peak time, peak overshoot and settling time of the system.

Answer:

$$\frac{C(s)}{R(s)} = \frac{\frac{4}{s(s+1)}}{1 + \frac{4}{s(s+1)}} = \frac{4}{s^2 + s + 4}$$

Comparing it with the standard form of the closed-loop transfer function of a second-order system,

$$\frac{C(s)}{R(s)} = \frac{4}{s^2 + s + 4} = \frac{\omega_n^2}{s^2 + 2\xi\omega_n s + \omega_n^2}$$

$$\therefore \omega_n^2 = 4$$

$$\text{i.e. } \omega_n = \sqrt{4} = 2$$

$$2\xi\omega_n = 1$$

$$\text{i.e. } \xi = \frac{1}{2\omega_n} = \frac{1}{2 \times 2} = 0.25$$

Since  $\xi < 1$ , the system is an underdamped one.

$$\omega_n = 2 \quad \text{and} \quad \xi = 0.25.$$

Therefore,

$$\omega_d = \omega_n \sqrt{1 - \xi^2} = 2 \times \sqrt{1 - 0.25^2} = 1.936 \text{ rad/s}$$

$$\theta = \tan^{-1} \frac{\sqrt{1 - \xi^2}}{\xi} = \tan^{-1} \frac{\sqrt{1 - 0.25^2}}{0.25} = 1.310 \text{ rad}$$

The rise time

$$t_r = \frac{\pi - \theta}{\omega_d} = \frac{3.141 - 1.310}{1.936} = 0.945 \text{ s}$$

The peak time

$$t_p = \frac{\pi}{\omega_d} = \frac{3.141}{1.936} = 1.622 \text{ s}$$

The peak overshoot

$$M_p = e^{-\xi/\sqrt{1-\xi^2}} = 0.4326$$

Therefore, percentage of peak overshoot is

$$M_p \times 100\% = 43.26\%$$

b. Determine the range of K for stability of a unity-feedback control system

whose open-loop transfer function is  $G(s) = \frac{K}{s(s+1)(s+2)}$

**Answer:**

**Characteristic equation:**

$$\begin{aligned} s(s+1)(s+2) + k &= 0 \\ &= (s^2 + s)(s+2) + k \\ &= s^3 + 2s^2 + s^2 + 2s + k = s^3 + 3s^2 + 2s + k = 0 \end{aligned}$$

**Routh array:**

$s^3$	1	2
$s^2$	3	k
$s^1$	$(6 - k) / 3$	0
$s^0$	k	

**For stability ..**

$$6 - k > 0 \quad k < 6$$

**range of k for stability**

$$0 < k < 6$$

**Q.7** a. Obtain Bode plot for the system represented by

$$H(\omega) = \frac{j\omega + 10}{j\omega(j\omega + 5)^2}$$

**Answer:**

1. Putting  $H(\omega)$  in the standard form, we get

$$H(\omega) = \frac{0.4(1 + j\omega/10)}{j\omega(1 + j\omega/5)^2}$$

From this, we obtain the magnitude and phase as:

$$\begin{aligned} H_{dB} &= 20 \log_{10} 0.4 + 20 \log_{10} \left| 1 + \frac{j\omega}{10} \right| - 20 \log_{10} |j\omega| \\ &\quad - 40 \log_{10} \left| 1 + \frac{j\omega}{5} \right| \\ \phi &= 0^\circ + \tan^{-1} \frac{\omega}{10} - 90^\circ - 2 \tan^{-1} \frac{\omega}{5} \end{aligned}$$



There are two corner frequencies at  $\omega = 5, 10$  rad/s. For the pole with corner frequency at  $\omega = 5$ , the slope of the magnitude plot is  $-40$  dB/decade and that of the phase plot is  $-90^\circ$  per decade due to the power of 2.

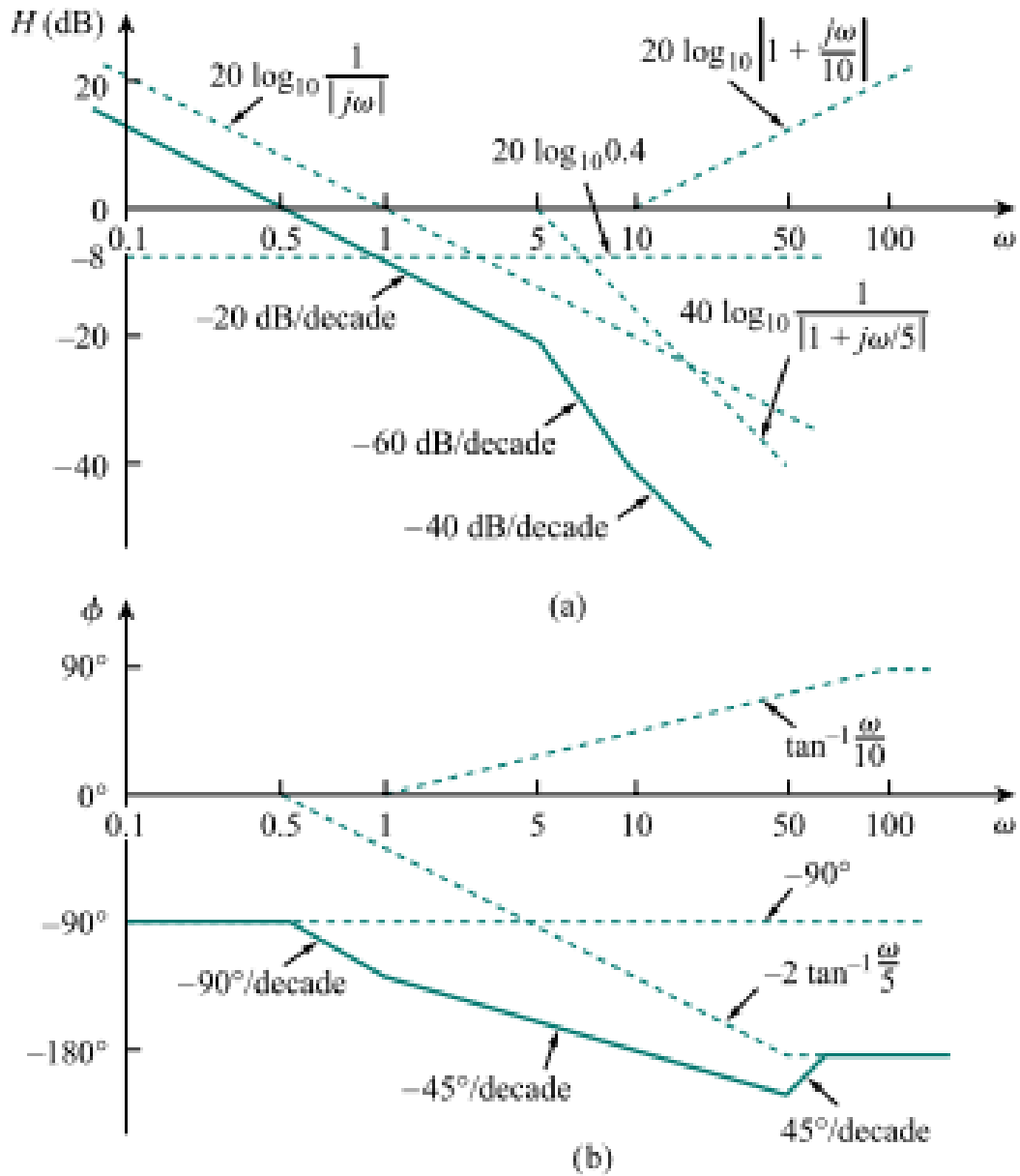

Also determine the Phase margin and Gain margin of the system.

b. Draw the complete Nyquist plot for a unity feedback system having the open loop function  $G(s) = \frac{6}{s(1+0.5s)(6+s)}$  from the plot evaluate absolute and relative stability of the system.

Answer:

Ans :

$$G(s)H(s) = \frac{6}{s(1+0.5s)(6+s)}$$

$$G(j\omega) \text{ at } \omega = 0 = \infty \angle -90^\circ \qquad G(j\omega) \text{ at } \omega \rightarrow \infty = 0 \angle 90^\circ$$

$$G(j\omega) = \frac{6}{(0.5s^2 + s)(s+6)} \Big|_{s=j\omega}$$

$$= \frac{6}{(-0.5\omega^2 + j\omega)(j\omega + 6)} = 6(-0.5\omega^2 - j\omega)$$

Nyquist contour is given by Semicircle around the origin represented by  $S = Re^{j\theta}$

$\theta$  varying from  $-90^\circ$  through  $0^\circ$  to  $90^\circ$

Maps into

$$\text{Lim}_{\omega \rightarrow 0} \frac{6}{6e^{-j90^\circ} (1+0.5e^{j90^\circ})(1+1/6e^{j90^\circ})} = \infty$$

$-90^\circ$  through  $0^\circ$  to  $90^\circ$   
mapping of positive imaginary axis ( $\omega = 0+$  to  $\infty+$ )

calculate magnitude and phase values of T.F

$$\frac{6}{6j\omega(1+0.5j\omega)(1+1/6j\omega)} \text{ at various values of } \omega$$

	1	10	50	100	500
magnitude	-1.085	-39.89	-80.389	-98.39	-140.32
phase	234	132.37	99.16	94.59	90.91

Mapping of infinite semicircular arc of the nyquist contour represented by

$$S = Re^{j\theta} \ (\theta \text{ varying from } +90 \text{ through } 0 \text{ to } -90 \text{ as } R \rightarrow \infty)$$

$$= \text{Lim}_{R \rightarrow \infty} \frac{1}{Re^{j\theta} (1+0.5Re^{j\theta})(1+0.166Re^{j\theta})}$$

$$= 0 e^{-j\theta}$$

$-270^\circ$  through  $0^\circ$  to  $-270^\circ$

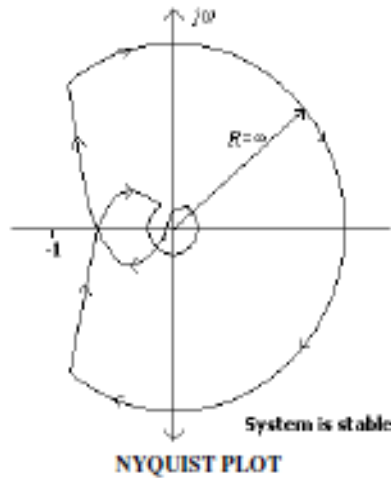

The system is stable and the relative stability is represented by phase margin and gain margin.

Gain margin = 18.1 ,Phase cross frequency = 3.46 rad/sec.

Phase margin = 57.2 , Gain cross frequency = 0.902 rad/sec

**Q.8 a.** Consider the control system shown in Fig.4 below in which a proportional compensator is employed. A specification on the control system is that the steady-state error must be less than two per cent for constant inputs. Find  $K_C$  that satisfies this specification.

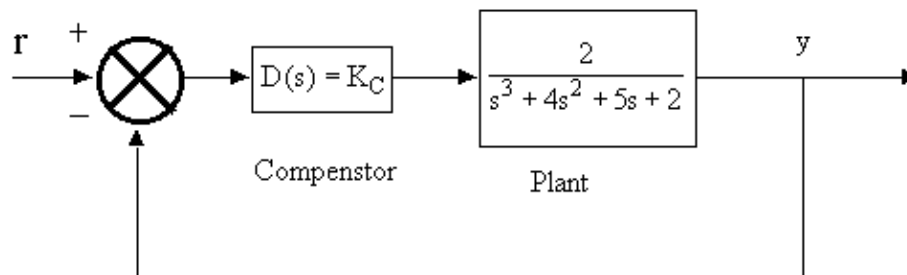

**Fig.4**

**Answer:**

$s^3$	1	5	0
-------	---	---	---

$s^2$	4	$2+2K_C$	0
$s^1$	$(18-2K_C)/4$	0	0
$s^0$	$2+2K_C$	0	

The system is stable for  $K_C < 9$ .

$$K_p \lim_{s \rightarrow 0} D(s)G(s) = K_C;$$

=

$e_{ss} = 1/(1+K_C)$ ;  $e_{ss} = 0.1$  (10 %) is the minimum possible value for steady state error. Therefore  $e_{ss}$  less than 2 % is not possible with proportional compensato

- b. Explain a technique to obtain magnitude and phase frequency characteristics of phase lag compensator.

**Answer:**

**Phase lag compensator**

Consider the following circuit. This circuit

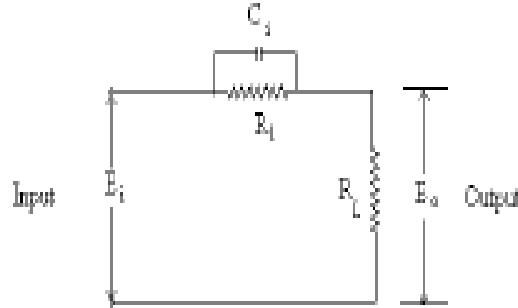

Where  $T_1 = R_1 C_1$  and  $T_2 = R_2 / (R_1 + R_2) T_1$

Obviously  $T_1 > T_2$ . For getting the frequency response of the network, but  $s = j\omega$  i.e.,

$$\left| \frac{E_o}{E_i} \right| = \frac{T_2}{T_1} \sqrt{\frac{1 + \omega^2 T_1^2}{1 + \omega^2 T_2^2}} \tag{2}$$

And phase  $\phi = \tan^{-1} \omega T_1 - \tan^{-1} \omega T_2$

Let us consider the polar plot for this transfer function as shown in figure below. We can observe that at low frequencies, the magnitude is reduced being  $T_2 / T_1$  at  $\omega = 0$ .

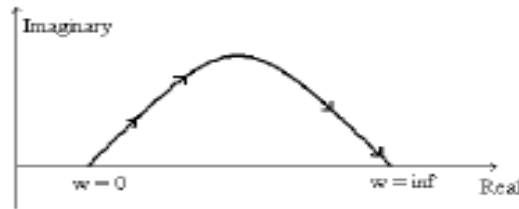

Next, let us consider the bode plot the transfer function as shown in figures below.

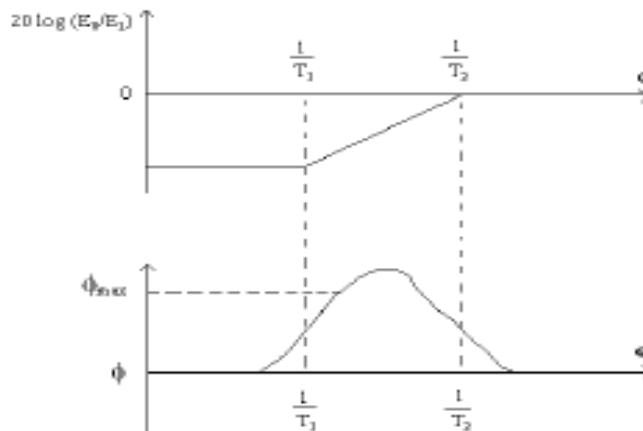

We observe here that phase  $\phi$  is always positive. From magnitude plot we observe that transfer function has zero db magnitude at  $\omega = 1 / T_2$ .

We can put  $d\phi / d\omega = 0$  to get maximum value of  $\phi$  which occurs at some frequency  $\omega_m$

$$\text{i.e., } w_m = 1 / (\sqrt{T_1 / T_2})$$

$$\phi_{\max} = \tan^{-1} [T_1 / T_2]^{1/2} - \tan^{-1} [T_2 / T_1]^{1/2}$$

In this network we have an attenuation of  $T_2 / T_1$  therefore, we can use an amplification of  $T_1 / T_2$  to nullify the effect of attenuation in the phase network.

**Q.9** a. Obtain the transfer function of the given state equation:

$$\dot{x} = \begin{bmatrix} 0 & 1 \\ -8 & -6 \end{bmatrix} x + \begin{bmatrix} 0 \\ 1 \end{bmatrix} u$$

$$y = [1 \quad 1]x$$

**Answer:**

Can obtain transfer function by inspection (special case)

$$\begin{aligned} G(s) &= C[sI_n - A]^{-1}B + D \\ &= [1 \quad 1] \left\{ \begin{bmatrix} 2 & 0.5 \\ -4 & -1 \end{bmatrix} + \frac{\begin{bmatrix} -1 & -0.5 \\ 4 & 2 \end{bmatrix}}{s+4} \right\} \begin{bmatrix} 0 \\ 1 \end{bmatrix} \\ &= \frac{-0.5}{s+2} + \frac{1.5}{s+4} = \frac{s+1}{s^2+6s+8} \end{aligned}$$

- b. Consider the linear continuous-time dynamic system represented by transfer function  $H(s) = (s+3)/(s+1)(s+2)(s+3)$ . Evaluate whether the system is
- completely controllable
  - completely observable

**Answer:**

$$\begin{bmatrix} \dot{x}_1 \\ \dot{x}_2 \\ \dot{x}_3 \end{bmatrix} = \begin{bmatrix} -6 & -11 & -6 \\ 1 & 0 & 0 \\ 0 & 1 & 0 \end{bmatrix} \begin{bmatrix} x_1 \\ x_2 \\ x_3 \end{bmatrix} + \begin{bmatrix} 1 \\ 0 \\ 0 \end{bmatrix} u$$

$$y = [0 \quad 1 \quad 3] \begin{bmatrix} x_1 \\ x_2 \\ x_3 \end{bmatrix}$$

It is easy to show that the controllability and observability matrices are given by

$$C = \begin{bmatrix} 1 & -6 & 25 \\ 0 & 1 & -6 \\ 0 & 0 & 1 \end{bmatrix}, \quad O = \begin{bmatrix} 0 & 1 & 3 \\ 1 & 3 & 0 \\ -3 & -11 & -6 \end{bmatrix}$$

Since

$$\det C = 1 \neq 0 \Rightarrow \text{rank} C = 3 = n$$

and

$$\det O = 0 \Rightarrow \text{rank} O < 3 = n$$

this system is controllable, but unobservable.

Note that, due to a zero-pole cancellation at  $s = -3$ , the system transfer function  $H(s)$  is reducible to

$$H(s) = H_r(s) = \frac{1}{(s+1)(s+2)} = \frac{1}{s^2 + 3s + 2}$$

so that the equivalent system of order  $n = 2$  has the corresponding state space form

$$\begin{bmatrix} \dot{x}_{1r} \\ \dot{x}_{2r} \end{bmatrix} = \begin{bmatrix} -2 & -3 \\ 1 & 0 \end{bmatrix} \begin{bmatrix} x_{1r} \\ x_{2r} \end{bmatrix} + \begin{bmatrix} 1 \\ 0 \end{bmatrix} u$$

$$y = [0 \quad 1] \begin{bmatrix} x_{1r} \\ x_{2r} \end{bmatrix}$$

For this reduced-order system we have

$$C = \begin{bmatrix} 1 & -2 \\ 0 & 1 \end{bmatrix}, \quad O = \begin{bmatrix} 0 & 1 \\ 1 & 0 \end{bmatrix}$$

### Text Book

Control Systems Engineering, I.J. Nagrath and M. Gopal, 5th Edition (2007 New Age International Pvt. Ltd.)